

Part number:

HYDROMA

HYDRAULICKÉ SYSTÉMY

**HIDROMA
SYSTEMS**

UKŁADY HYDRAULICZNE

HYDROMA

ГИДРАВЛИЧЕСКИЕ СИСТЕМЫ

FTA-FTB-KTS

TRANSMISSION FILTERS

MATERIALS

Head: Aluminium alloy
Cover: Polyamide FTA-FTB23
Aluminium alloy FTA-FTB31-32-33
Bowl: Steel
Seals: NBR Nitrile
Indicator housing: Brass

PRESSURE

Max working: 1 MPa (10 bar)
Collapse, differential for the filter element (ISO 2941):
1 MPa (10 bar)

BYPASS VALVE

Setting: 250 kPa (2,5 bar) \pm 10%

WORKING TEMPERATURE

From -25° to + 110° C

COMPATIBILITY (ISO 2943)

Full with fluids: HH-HL-HM-HV-HTG
(according to ISO 6743/4)
For fluids different than the above mentioned,
please contact our Customer Service

HYDRAULIC DIAGRAM

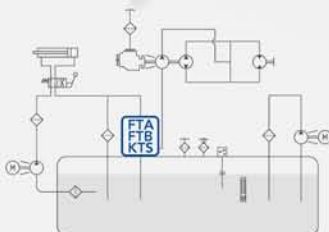



FTA-FTB

TRANSMISSION FILTERS

ORDERING AND OPTION CHART

F	T	COMPLETE FILTER FAMILY							
		A = with internal bypass							
		B = with external bypass							
								FILTER ELEMENT FAMILY	E T A
		SIZE & LENGTH	23	31	32	33		SIZE & LENGTH	
	B	PORT TYPE							
		B = BSP thread	B	B	B	B			
		PORT SIZE							
		D3 = 3/4" suction + 3/4" return	D3	-	-	-			
		D4 = 3/4" suction + 1" return	D4	-	-	-			
		T1 = 1 1/4" return + 2x1" suction	-	T1	T1	T1			
	B	BYPASS VALVE							
		B = 250 kPa (2,5 bar) return	B	B	B	B			
	N	SEALS						SEALS	N
		N = NBR Nitrile	N	N	N	N			
		FILTER MEDIA *						FILTER MEDIA	
		FC = fibreglass 12 µm _(c) β>1.000	FC	FC	FC	FC			
		FS = fibreglass 16 µm _(c) β>1.000	FS	FS	FS	FS			
		CLOGGING INDICATOR							
		05 = nr. 2 x 1/8" ports, plugged	05	05	05	05			
		30 = pressure gauge, rear connection	30	30	30	30			
		P6 = SPDT, pressure switch	P6	P6	P6	P6			
		ACCESSORIES							
		A = pressurisation valve	A	A	A	A			
		B = press. valve + drain hole	B	B	B	B			
		C = press. valve + suction bypass	C	C	C	C			
		D = press. valve + drain hole + suction bypass	D	D	D	D			
	X	ACCESSORIES							
		X= no other accessory available	X	X	X	X			

SPARE PARTS ELEMENTS

FILTER HOUSING		FILTER ELEMENT		CLOGGING INDICATOR		ACCESSORIES	
							
B	T	B	N	E	T	A	N

KTS

TRANSMISSION FILTERS

ORDERING AND OPTION CHART

K	T	S	COMPLETE FILTER FAMILY					FILTER ELEMENT FAMILY	C	K	T
			SIZE & LENGTH	110	210	220	230	SIZE & LENGTH			
			FILTER MEDIA*					FILTER MEDIA			
			FD = fibreglass 12 $\mu\text{m}_{(0)}$ $\beta > 1.000$	FD	FD	FD	FD				
			FS = fibreglass 16 $\mu\text{m}_{(0)}$ $\beta > 1.000$	FS	FS	FS	FS				
		1	SEALS					SEALS	1		
			1 = NBR Nitrile	1	1	1	1				
			BYPASS TYPE								
			B = Internal 250 kPa (2,5 bar)	B	B	B	B				
			T = External 250 kPa (2,5 bar)	T	T	T	T				
		B	PORT TYPE								
			B = BSP thread	B	B	B	B				
			PORT SIZE								
			4 = 3/4" suction + 3/4" return	4	-	-	-				
			D = 3/4" suction + 1" return	D	-	-	-				
			E = 1 1/4" return + 2x1" suction	-	E	E	E				
			CLOGGING INDICATOR								
			05 = nr. 2 x 1/8" ports, plugged	05	05	05	05				
			30 = pressure gauge, rear connection	30	30	30	30				
			P6 = SPDT, pressure switch	P6	P6	P6	P6				
			ACCESSORIES								
			A = pressurisation valve	A	A	A	A				
			B = press. valve + drain hole	B	B	B	B				
			C = press. valve + suction bypass	C	C	C	C				
			D = press. valve + drain hole + suction bypass	D	D	D	D				
		X	ACCESSORIES								
			X = no other accessory available	X	X	X	X				

SPARE SEAL KIT

	NBR	FKM
FTA2-FTB2 KTS1	521.0121.2	521.0122.2
FTA3-FTB3 KTS2	521.0123.2	521.0124.2

* For any different media requirement, please check availability with our Customer Service

FTA-FTB-KTS

TRANSMISSION FILTERS

INSTALLATION DRAWING

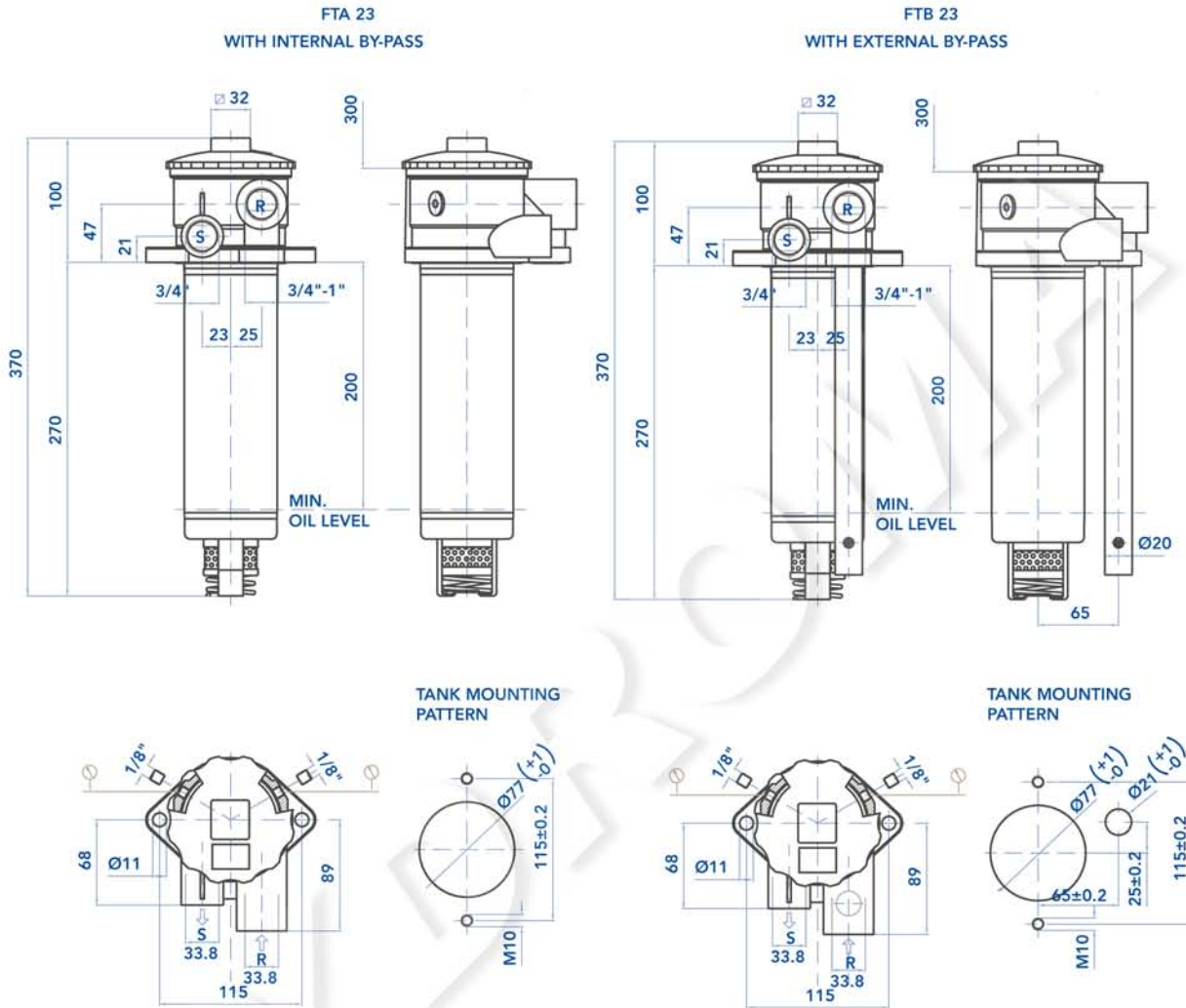

WORKING SCHEME

Options A and C
are recommended for horizontal filter mounting.

Options B and D
are recommended for vertical filter mounting (drain hole).

Options C and D
a 125 µm strainer protects the emergency valve in case of brief lack of oil in the suction of the boost pump (situation to be anyway avoided)

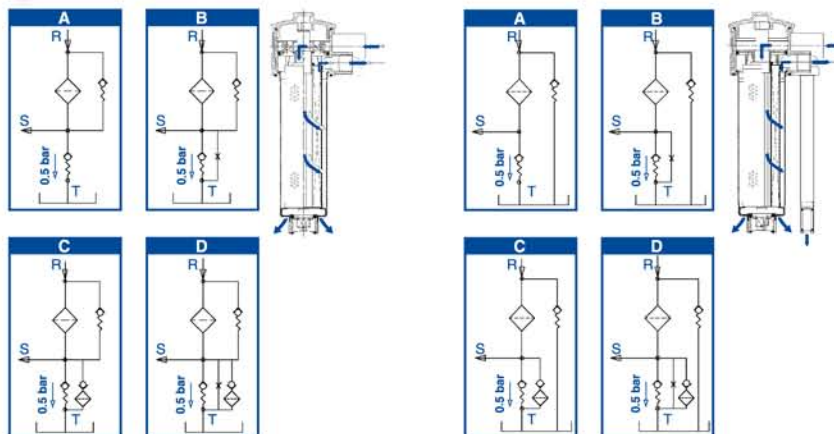

INSTALLATION DRAWING

FTA 31 - 32 - 33
WITH INTERNAL BY-PASS

FTB 31 - 32 - 33
WITH EXTERNAL BY-PASS

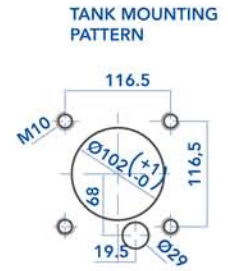
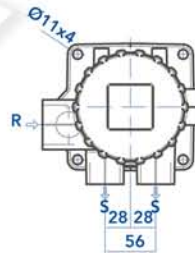
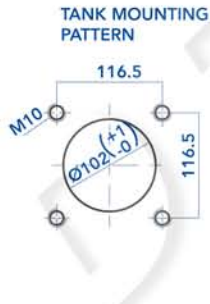
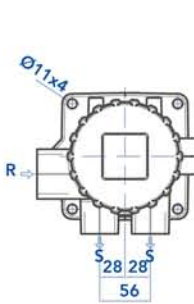
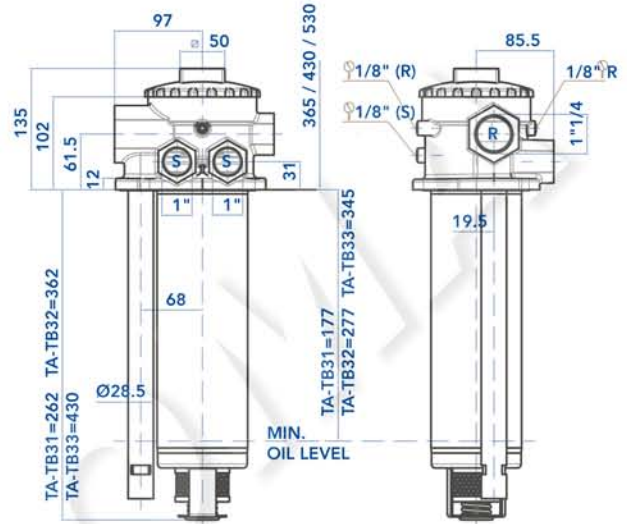
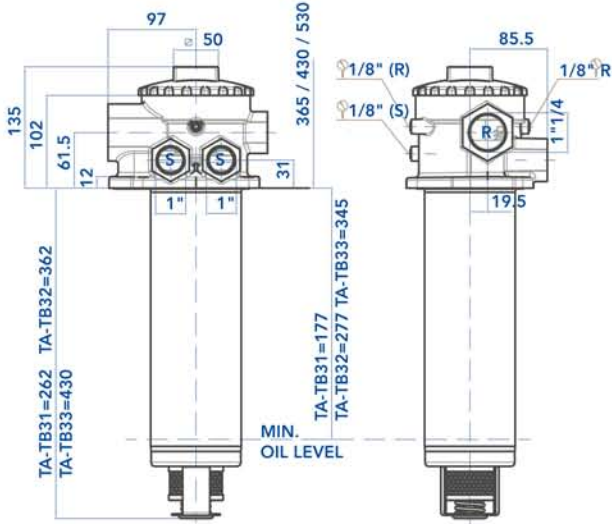

WORKING SCHEME

Options A and C are recommended for horizontal filter mounting.

Options B and D are recommended for vertical filter mounting (drain hole).

Options C and D a 125 µm strainer protects the emergency valve in case of brief lack of oil in the suction of the boost pump (situation to be anyway avoided)

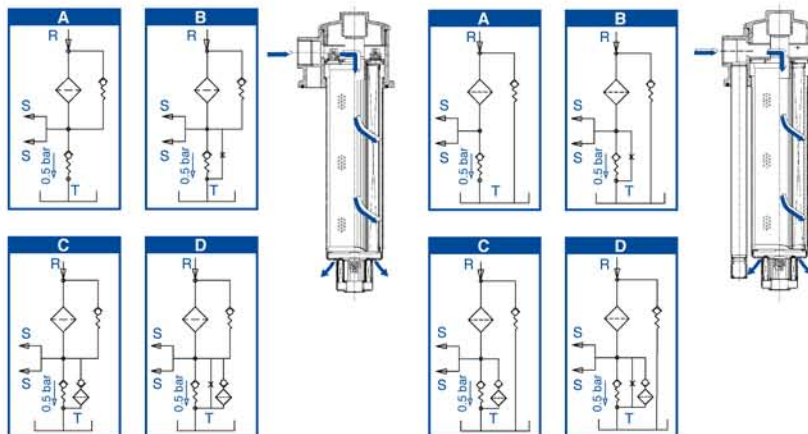

FTA-FTB-KTS

TRANSMISSION FILTERS

MAINTENANCE

The best time to change your filter element is just before it reaches its maximum dirt-holding capacity. For this reason, we recommend to monitor the pressure of the hydraulic oil flowing through the filter with a clogging indicator. When it is time to change the filter element, switch off the system before opening the filter housing.

Unscrew the plug and extract the handle from the housing. Remove the dirty filter element and replace it with an original UFI element, verifying the part number on the filter label or on the catalogue. Clean the handle, check the handle O-Ring condition and lubricate with oil.

Check the gaskets conditions and replace if necessary. Insert the clean element on the shank of the handle, handling with care and cleanliness. Replace the handle complete with filter element in the housing ensuring the sealing of the gasket. Tighten the plug until it stops with the following tightening torques:

KTS 105-110 Series: 25 Nm +5/0

KTS 210-220-230 Series: 35 Nm +5/0

We recommend the stocking of a spare UFI filter element for timely replacement when required.



FILTER ELEMENT

	A	B	C	KG	AREA (cm ²) Media F+
ETA23 CKT110	63,5	28	230	0,40	1.900
ETA31 CKT210	90	40	232	0,55	2.800
ETA32 CKT220	90	40	333	0,77	4.100
ETA33 CKT230	90	40	400	0,85	4.900

The used filter elements cannot be cleaned and are classified as "Dangerous waste material". They must be disposed according to local laws by authorized Companies.

Verify that the Company you choose has the expertise and authorization to dispose this type of waste material.

PRESSURE DROP CURVES (Δp)

The "Assembly Pressure Drop (Δp)" is obtained by adding the pressure drop values of the Filter Housing and of the Clean Filter Element corresponding to the considered Flow Rate and it must

be lower than 40 kPa (0,4 bar) and should never exceed 1/3 of the bypass valve setting.

FILTER HOUSING PRESSURE DROP
(mainly depending on the port size)

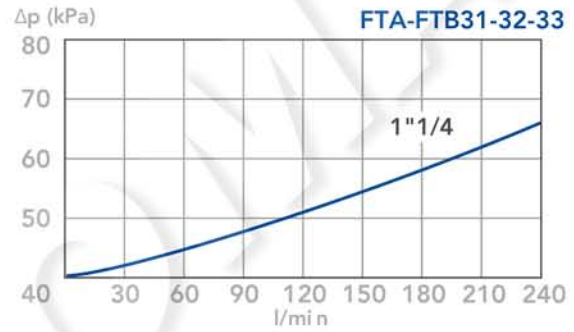
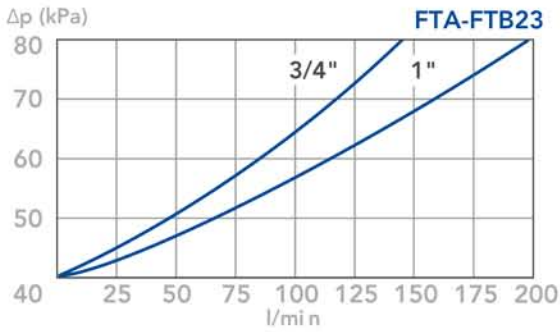

CLEAN FILTER ELEMENT PRESSURE DROP
(depending both on the internal diameter of the element and on the filter media)

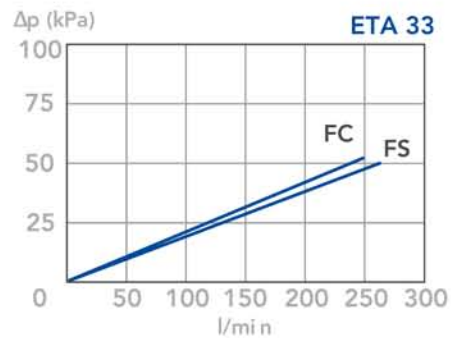
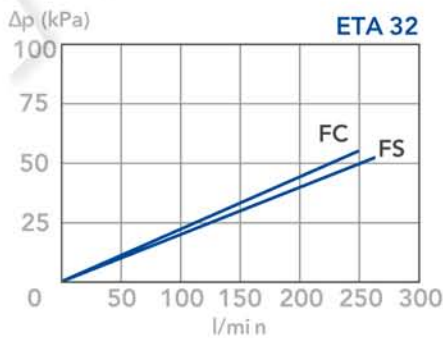
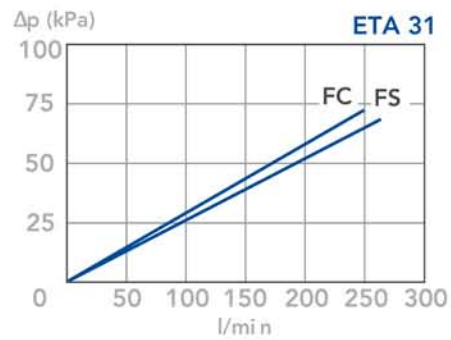
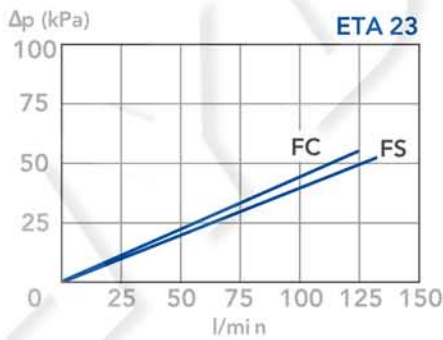

FTA-FTB-KTS

TRANSMISSION FILTERS

BYPASS VALVE PRESSURE DROP

When selecting the filter size, these curves must be taken into account if it is foreseen that any flow peak is to be absorbed by the bypass valve, it also must be of proper configuration to avoid pressure peaks. The valve pressure drop is directly proportional to fluid specific gravity.

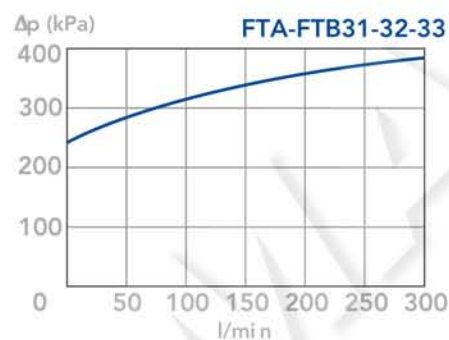
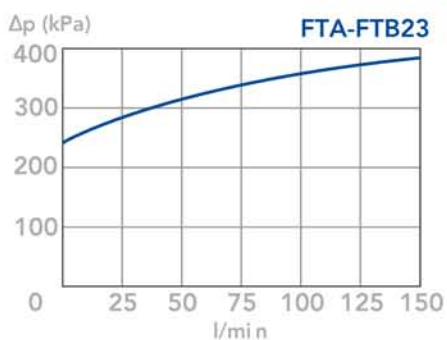

N.B.

All the curves have been obtained with mineral oil having a kinematic viscosity 30 cSt and specific gravity 0,86 kg/dm³; for fluids with different features, please consider the factors described in the first part of this catalogue. All the curves are obtained from test done at the UFI HYDRAULIC DIVISION Laboratory,

according to the specification ISO 3968.
In case of discrepancy, please check the contamination level, viscosity and features of the fluid in use.